

Hot Design Tips

For easy handrail compliance in a Class 9b building used as a primary school

As per **figure 1** handrails complying to BCA clause D2.17, a, iii, like our AR110 and AR140 configurations, must be installed on a substrate that allows a minimum 1000mm between handrails as stated in AS1428.1-2009 clause 6.3 and BCA clause D1.6, B, i.

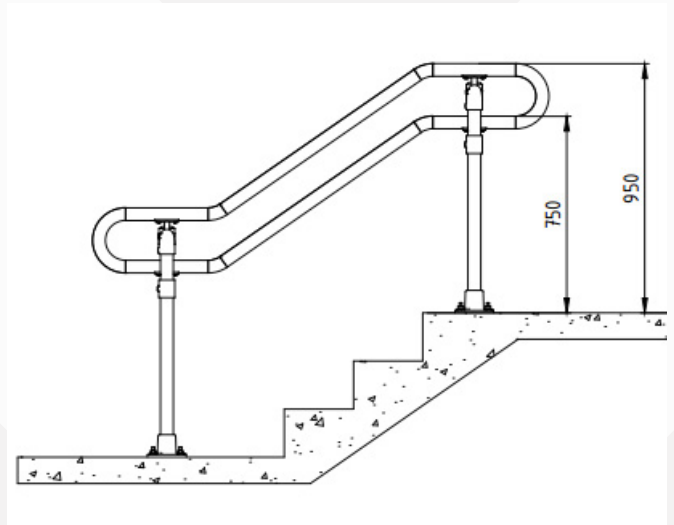

Figure 1

As per **figure 2** the minimum substrate width to achieve 1000mm between handrails using our AR110 configuration must be no less than 1401mm.

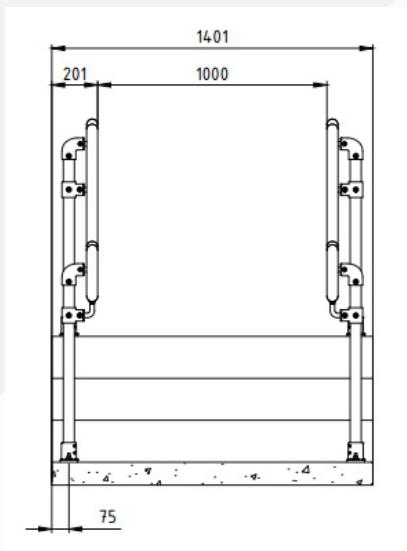

Figure 2

As per **figure 3** the minimum substrate width to achieve 1000mm between handrails using our AR110 and AR140 configurations must be no less than 2653mm.

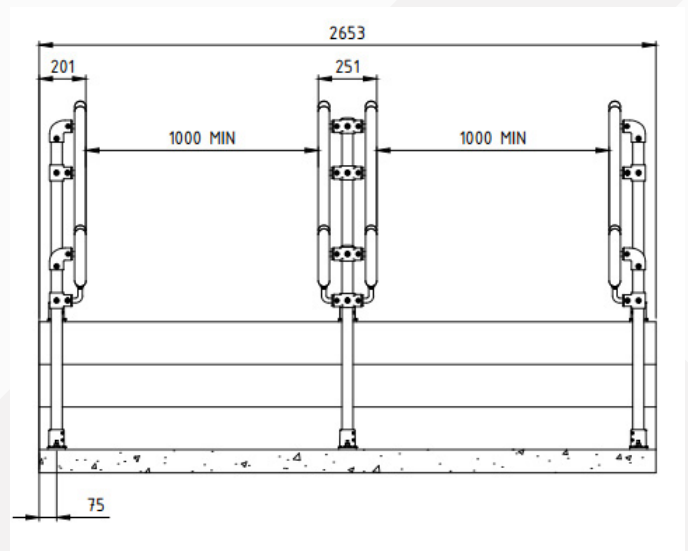

Figure 3