

## BRIDGERAIL™ AS5100.2 CL12.5 Compliant Balustrade Level - Standard 1.5 Mtr Spacing

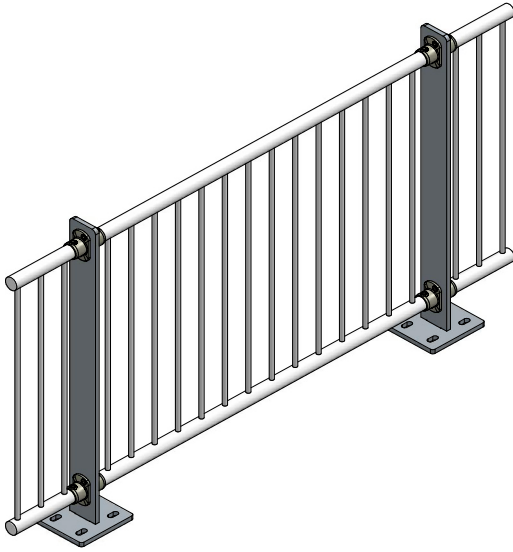

### Key features

- › Modular flexibility
- › No-weld assembly
- › Flat pack delivery
- › Reduced corrosion
- › Colour options
- › BIM & CAD Support

### Applications suited to

- › Cycle paths and bikeways
- › Shared pedestrian paths
- › Protection over culverts
- › Footbridges
- › Refer to applicable Aust Standards and Building Codes.

### Specification Summary

Supply and install the proprietary Bridgerail™ BR20 barrier system to substrate according to Moddex specifications, or by a Moddex accredited installer.

### Technical Data

#### Material

<b>Stanchions, rails &amp; balustrades</b>	Steel/grade 250 & C350
<b>Clamp fittings</b>	Ductile iron
<b>Clamp locking screws</b>	Stainless steel (304)

#### Protective coating

<b>Stanchions, rails and balustrades</b>	G390 Hot-dip Galvanized (min 390g/m <sup>2</sup> )
<b>Clamp fittings</b>	Hot-dip Galvanized with patented protective coating on threads
<b>Optional</b>	Powder coating and paint specs

\*The standard process for Powder Coated and Painted handrail products is as follows: black steel is used for fabrication. The steel is sand blasted and a zinc primer coating is applied. The powder coat / paint coat is then applied over the zinc primer creating a dual shield coating with a decorative finish.

### Dimensions

Variable depending on building/application/code

#### Stanchions

<b>Dimensions</b>	1155mm high
<b>Nominal Thickness</b>	16.0mm plate

#### Rails (Balustrade Panel)

<b>Diameter</b>	48.3mm OD
<b>Nominal Thickness</b>	3.25mm (medium wall applications) 4.0mm (heavy wall applications)

#### Base Plate

<b>Nominal Thickness</b>	16.0mm
--------------------------	--------

#### Balustrade

<b>Heavy Duty Baluster</b>	16mm
<b>Baluster Centres</b>	100mm (84mm gap)

#### Clamp fittings

<b>Thickness</b>	5.0mm (approx)
<b>Locking screws</b>	M12 x 1.75 x 11 mm - DEXX® Drive

#### Expansion Joint

<b>Diameter</b>	39 mm
<b>Length</b>	300.0mm
<b>Material</b>	Steel Hollow Bar

### Fixings

Stanchion attachment to

<b>Concrete</b>	M16 mechanical concrete anchors or cast in studs/ferrules as specified.
<b>Structural steel</b>	M16 galvanized high tensile bolt set

\*Other Fixing options are available on request

### Compliance

Moddex balustrades and handrails are designed and manufactured in accordance with Austroads Guide to Road Design and relevant statutory WHS Codes of Practice/Guidelines, including AS5100.2.2017 CL12.5. Galvanized to AS 4792 and AS/NZS 4680:2006 (where applicable).

The manufacture of Bridgerail proprietary systems is in accordance with Moddex specifications and manufacturing processes, and this may differ to some jurisdictional specifications for steelwork fabrication, bridges and related structures.

### Testing

Stringent vibration endurance tests have been performed and independent testing has been carried out to confirm the suitability of the Moddex system in maritime conditions.

### Warranty

5 years from date of purchase subject to correct installation, use and maintenance in accordance with manufacturer's specifications and recommendations, unless otherwise negotiated at the time of purchase.

— Refer maintenance manual

### Inspection & Maintenance

Visual inspection for any damage or loose fixings must be done periodically and prior to use. No certified maintenance required. Basic wear and tear preventative maintenance is recommended, as per manufacturer's specifications and recommendations.

— Refer maintenance manual

### Design Life

Standard design life of barrier is 100 years in C2 corrosivity zones.

## Technical Information

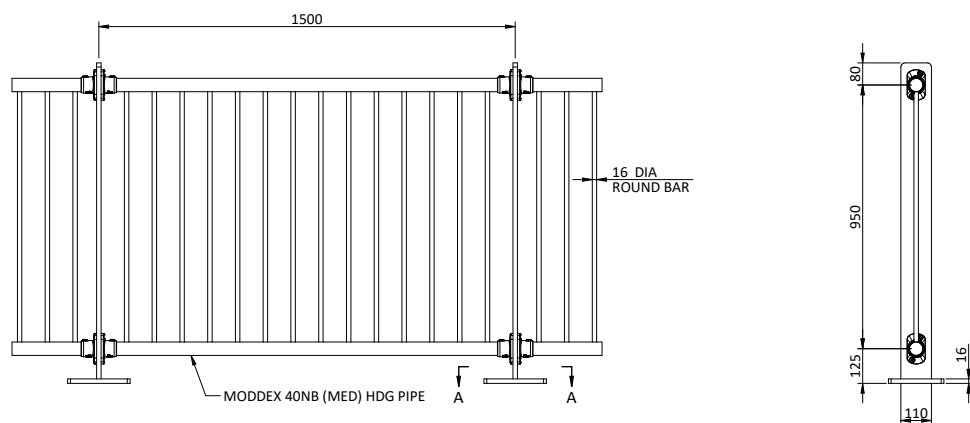

## Mount Dimensions

### T4 - Top Mount (4 Fixings)

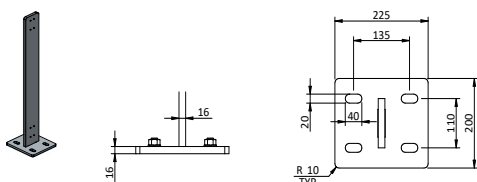

\*Face mount and custom mounting options available.

## Expansion Detail

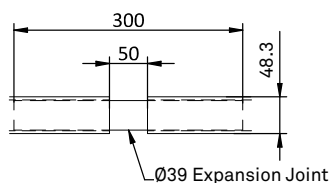

## Standard References

### Austrads Guide To Road Design; Part 6A

5.5.3 The installation of a fence at the side of a path used by cyclists is desirable where:

- there is a steep batter or large vertical drop located in close proximity to the path
- the path is adjacent to an arterial road and it is necessary to restrict cyclist access to the road
- a bridge or culvert exists on a path
- a hazard exists adjacent to a particular bicycle facility
- cyclists are likely to be 'blazing a separate trail' at an intersection between paths or around a path terminal.

### Australian Standard Bridge Design; Part 2

This Standard was prepared by the Standards Australia Committee BD-090, Bridge Design, to supersede AS 5100.2—2004. This Standard is also designated as Austrads publication AP-G51.2-17.

The objectives of the AS(AS/NZS) 5100 series are to provide nationally acceptable requirements for—

- (a) the design of road, rail, pedestrian and cyclist path bridges;
- (b) the specific application of concrete, steel, timber and composite construction, which embody principles that may be applied to other materials in association with relevant standards;
- (c) the assessment of the load capacity of existing bridges; and
- (d) the strengthening and rehabilitation of existing bridges.

The objective of this Part (AS 5100.2) is to specify minimum design loads and load effects for road, rail, pedestrian and cyclist path bridges, and other associated structures.

The requirements of the AS(AS/NZS) 5100 series are based on the principles of structural mechanics and knowledge of material properties, for both the conceptual and detailed design, to achieve acceptable probabilities that the bridge or associated structure being designed will not become unfit for use during its design life.

**Important Note:** Failure to supply and/or install proprietary product in accordance with above Standards and codes, specification and instructions, voids complete system certification and/or warranty.

Designed and manufactured by Moddex. ©Moddex Group. All Rights Reserved.

For information or technical support please contact us

T 1800 663 339 (AU)

T 0800 663 339 (NZ)

moddex.com